

EDV & Multimedia Interaktionsdesign

03 – Interaktive Performanz

Prof. Dr. Jochen Koubek



Ästhetik des Performativen

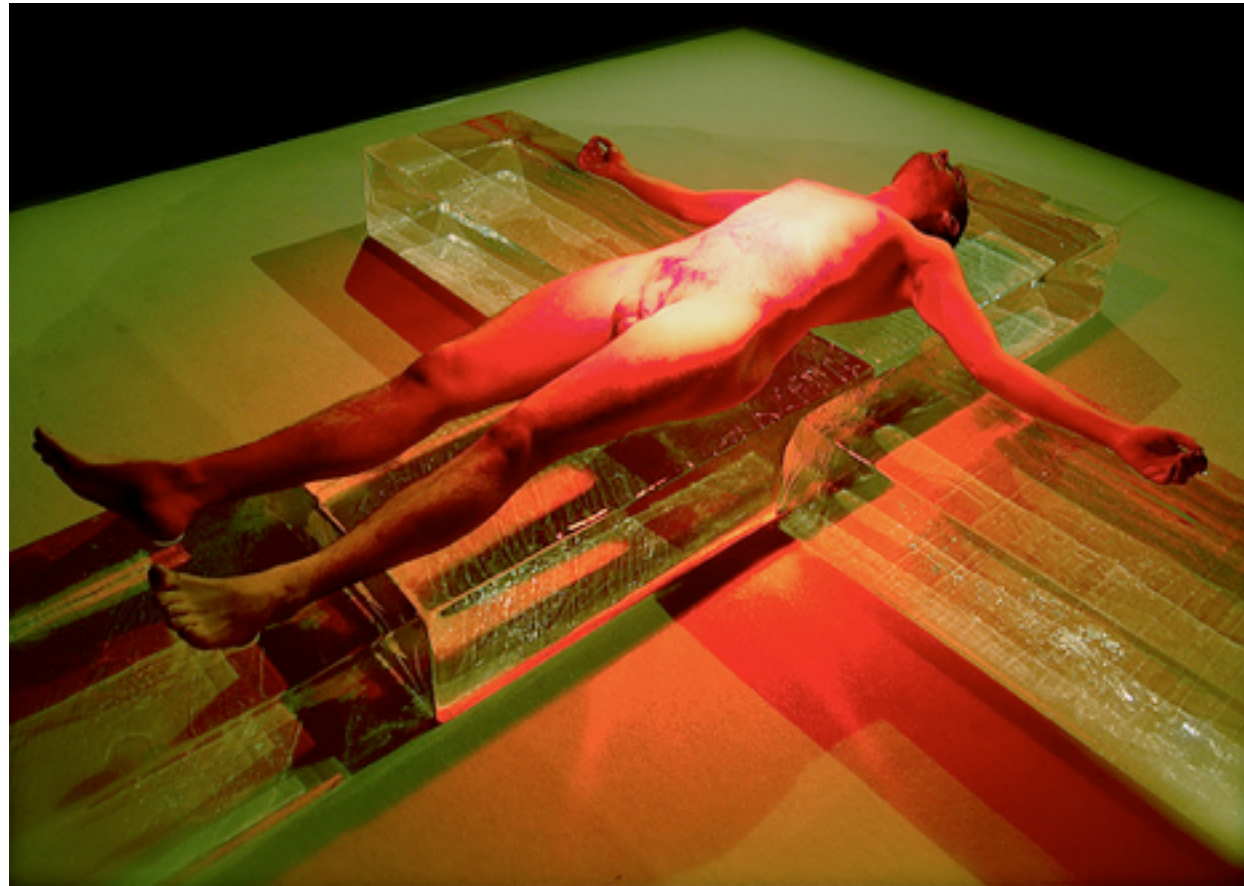

Abramovic: The Lips of Thomas

Ko-Präsenz von Aufführenden und Zuschauern

Hervorbringung von Materialität

Emergenz von Bedeutung

Aufführung als Ereignis

Autopoietische Feedback-Schleife

vgl. Erika Fischer-Lichte: Ästhetik des Performativen

Bühnentechnik



STAIRVILLE DJ LASE GR-140 RGY DMX



STAIRVILLE MATRIX FX-440 DMX



ANTARI Z-1200/ II DMX NEBELMASCHINE

DMX

Digital Multiplex



AMERICAN DJ GOBO PROJECTOR LED



AMERICAN DJ DEKKER LED



AMERICAN DJ LED COLOR BALL

DMX - Software

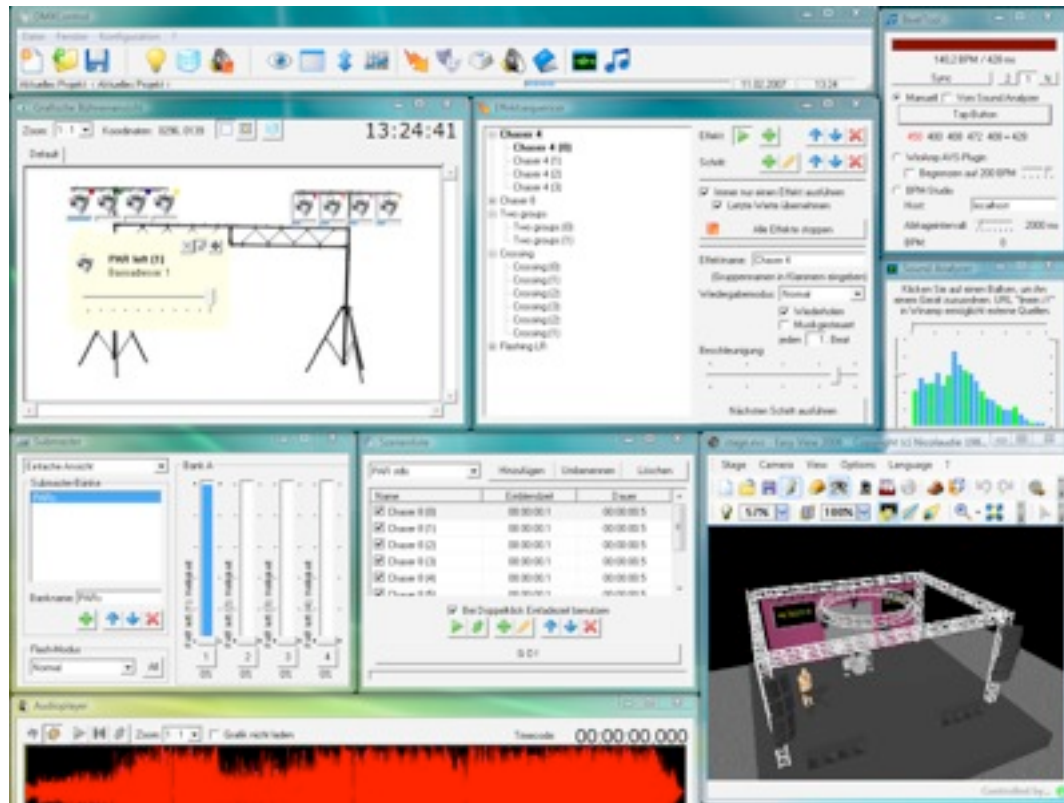

DMX Freestyler



DMX Control

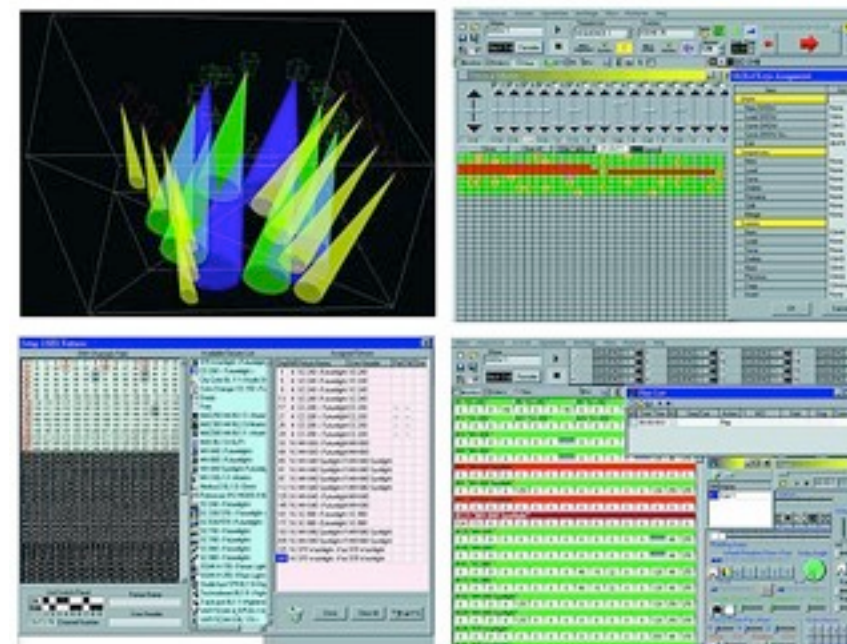

DMX Wizard

Musik

Golan Levin



Dialtones (A Telesymphony) (2001-2002: Golan Levin, Gregory Shakar, Scott Gibbons, Yasmin Sohrawardy, Joris Gruber, Erich Semlak, Gunther Schmidl, Joerg Lehner, and Jonathan Feinberg)

<http://vimeo.com/4166428>

Instrumente

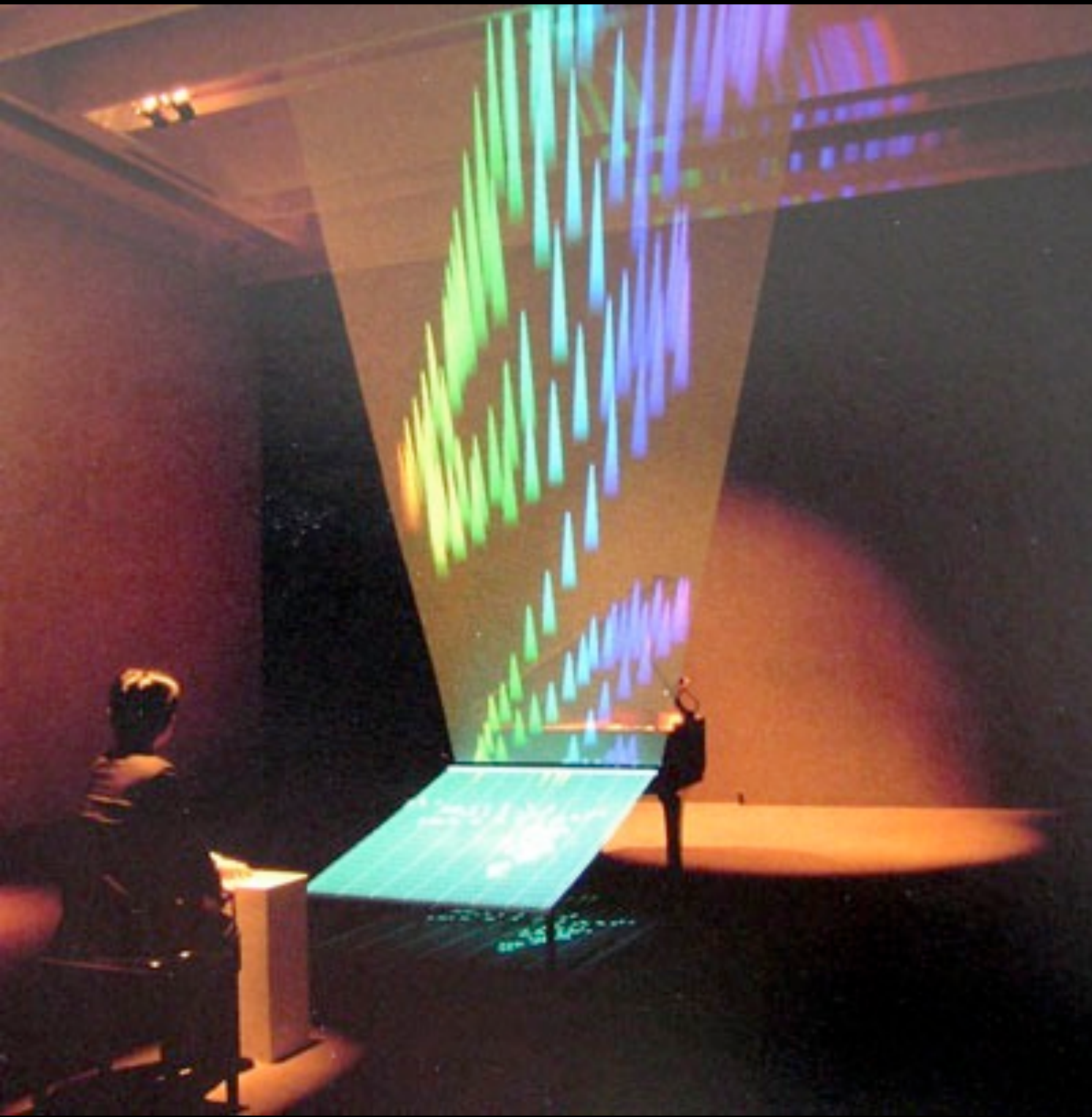

Toshio Iwai, 'Piano - as image media', 1995.
<http://www.youtube.com/watch?v=3a9dOoLU5xQ>



<http://www.stephenhobley.com/blog/laser-harp-2009/>

Quartett

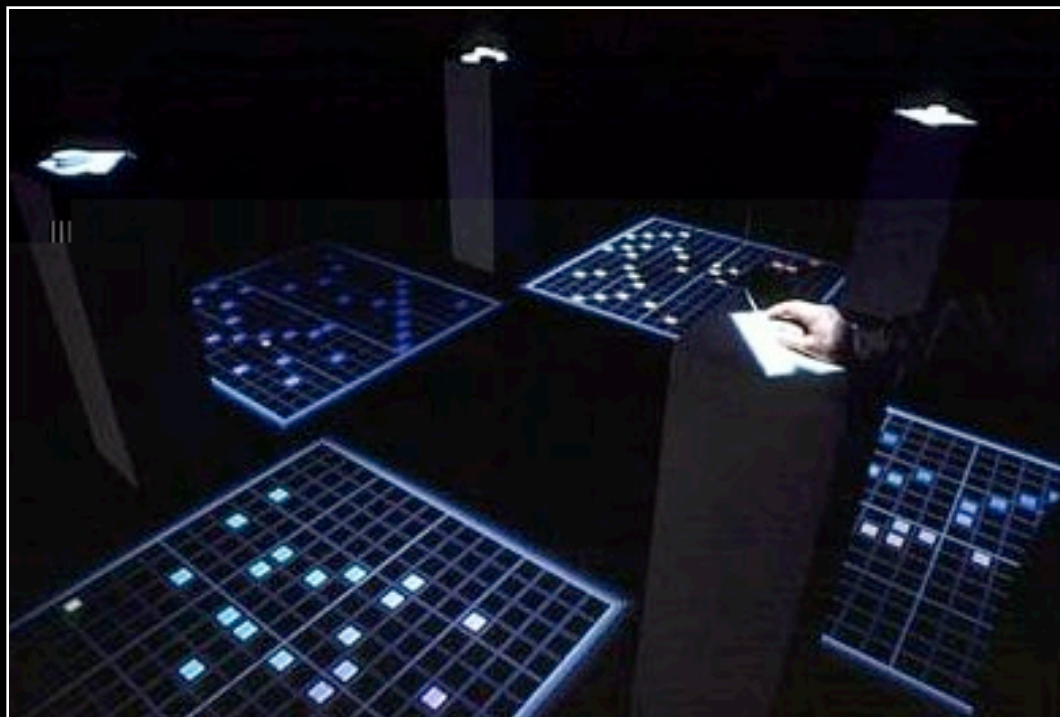
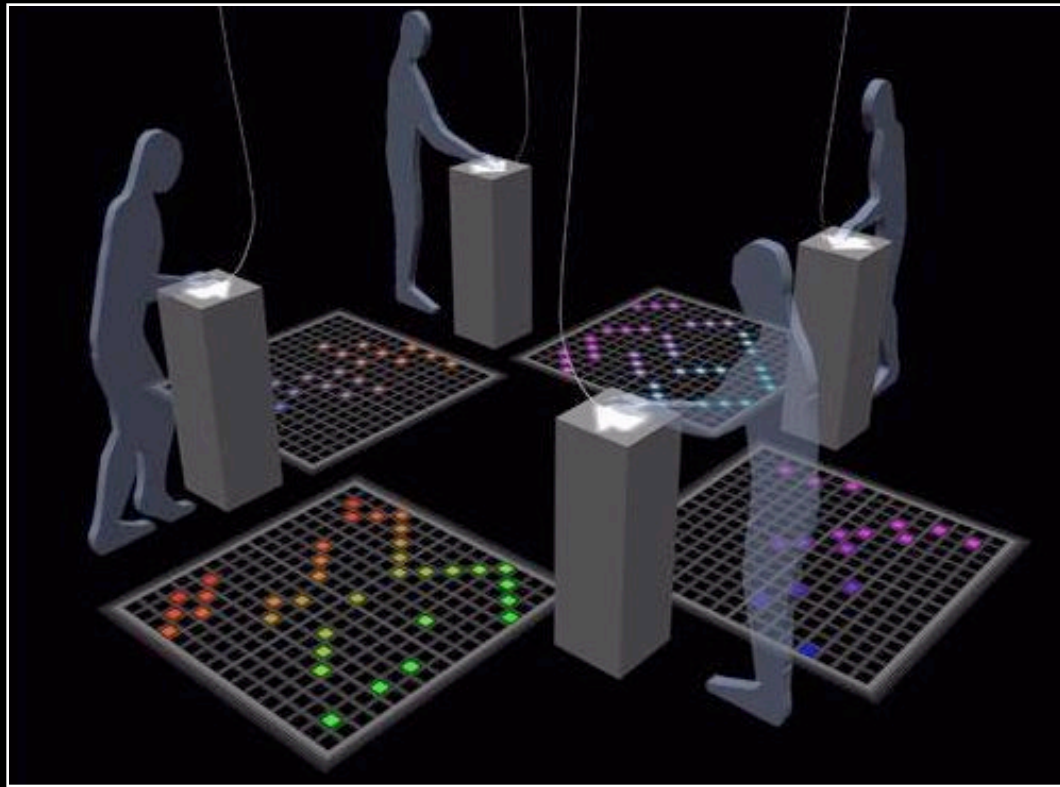

'resonance of 4' by the Japanese artist Toshio Iwai

<http://pauillac.inria.fr/~codognet/VR.html>

New Music for the Masses

http://www.adobe.com/uk/designcenter/thinktank/ttap_music/



Audiopad

<http://www.youtube.com/watch?v=59zS7m23lsM>



Composition on the Table [PUSH]

<http://www.youtube.com/watch?v=Q6LWqmaaPyU>

Tenori-On

Toshio Iwai, 2007

http://www.youtube.com/watch?v=_SGwDhKTrwU

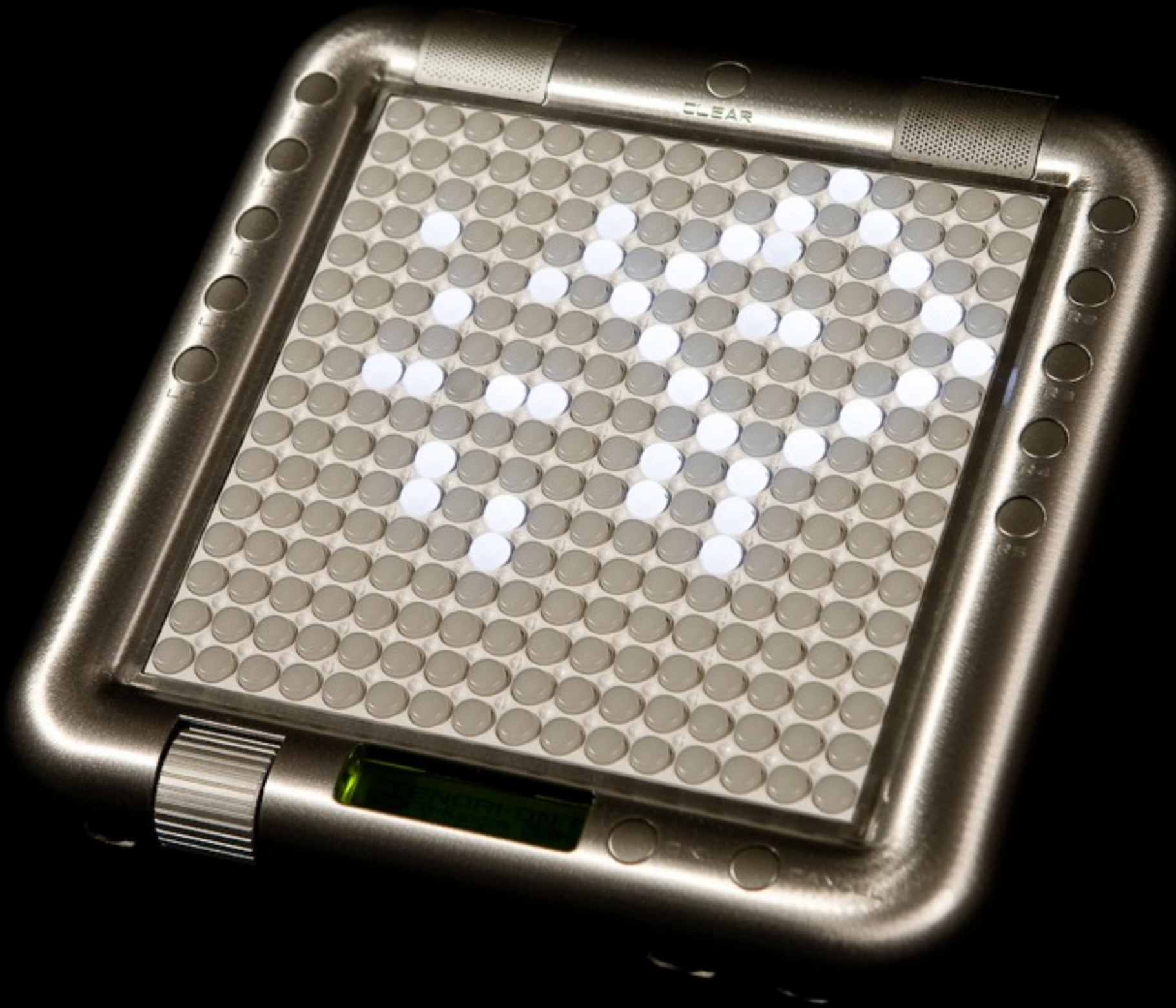



Reactable

<http://www.youtube.com/watch?v=0h-RhyopUmc>

Ball Droppings

<http://balldroppings.com/js/>

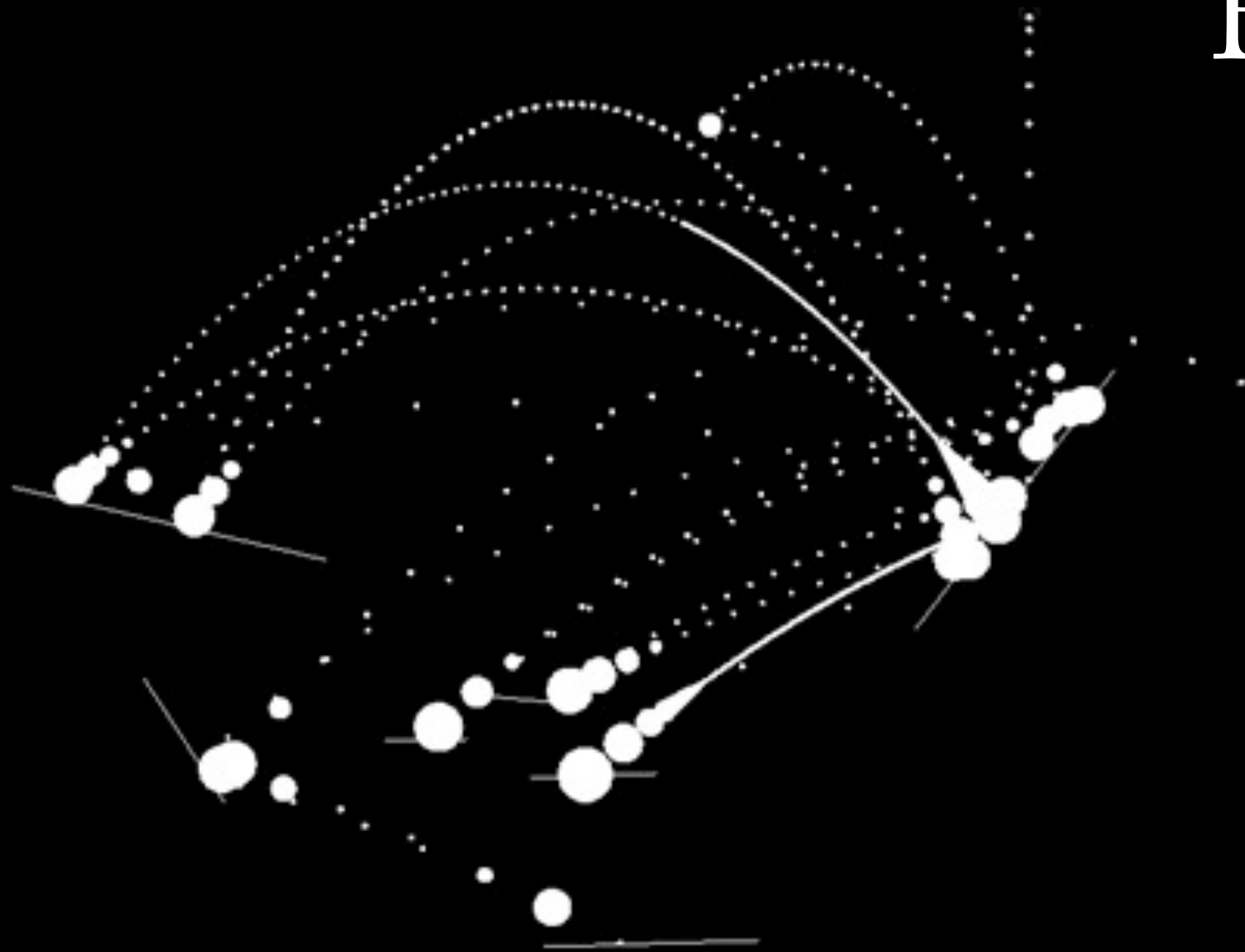

Circuit Bending

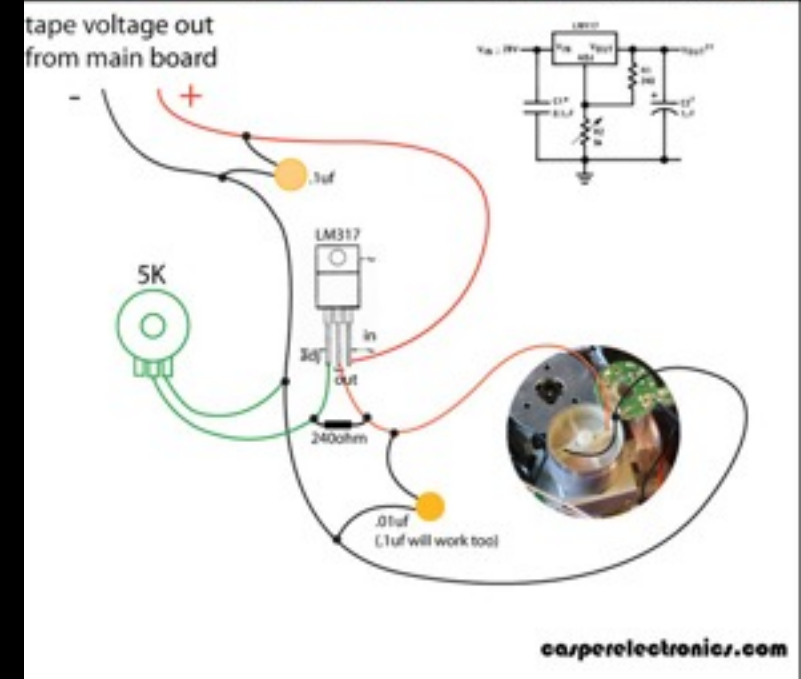
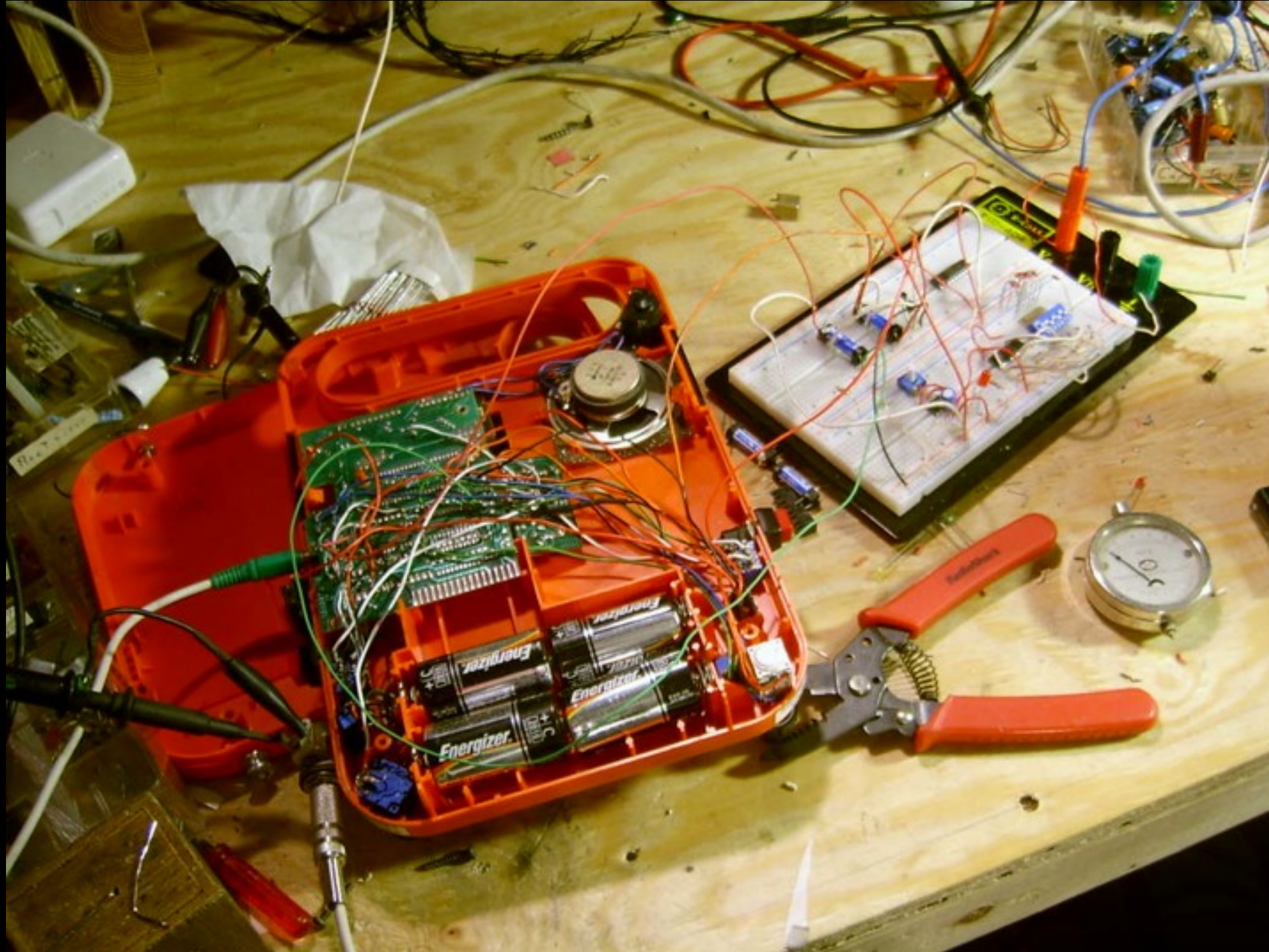

Das Kombinat



Im ehemaligen digitalen Studio am Audimax entstand mit dem Kombinat eine Projektgemeinschaft und Austauschplattform von Studenten, welche sich in erster Linie dem Produzieren von digitaler/elektronischer Musik und dem Programmieren von Visualisierungen aller Art widmen.

Neben den klassischen Anwendungsbereichen im audiovisuellen Feld soll durch die experimentelle Beschäftigung mit den Verfahren der Soundproduktion und der Projektionskunst (z.B. Video Mapping) auch der Einsatz digitaler Medien in Theaterprojekten gefördert werden. Es wird den Studenten somit ermöglicht, sich in einem weiteren wichtigen Schnittfeld von Theater und Medien kreativ zu betätigen.

Software: Max/MSP/Jitter, Ableton Live, VVVV, Processing, Arduino, Pure Data ...

Wöchentliches Treffen: Donnerstags, 18 Uhr im S 95 neben dem Audimax.

Kontakt: daskombinat@googlemail.de

Virtuelle

Gespiegelte

Hybride

Künstliche

Körper

Merce Cunningham

Hand-Drawn Spaces

<http://openendedgroup.com/index.php/artworks/hand-drawn-spaces-1998/>





A String



lee jaegon (2006): **A String**
<http://tokage.cafe24.com/string.htm>

Body Navigation



Ole Kristensen: Body Navigation, 2008.
<http://3xw.ole.kristensen.name/works/body-navigation/>

Animata



<http://www.kitchenbudapest.hu/en/node/244>

Kinect

Live Looping with Ableton and Xbox Kinect

<http://www.youtube.com/watch?v=xPcoM7BIDZ4>



Stelarc



Ping Body, 1996

<http://www.youtube.com/watch?v=wTYYJZG0f68>

Louis-Philippe Demers

<http://processing-plant.com/>



Devolution 2006

<http://www.youtube.com/watch?v=07ZaN471Jbl>

Raum

Real Reality

Augmented Reality

Mixed Reality

Augmented Virtuality

Virtual Reality

Surveillance Camera Players

<http://www.youtube.com/watch?v=RILTl8mxEnE>



God's Eyes, 2000



Robert Lepage

<http://lacaserne.net/index2.php/robertlepage/>

Ex Machina

