

KLASSIKER DER SPIELEGESCHICHTE



14 FAN-PROJEKTE UND INDEPENDENT - SPIELE

10. FEBRUAR 2011

Mystery House Taken Over



<http://turbulence.org/Works/mystery/>

Spielbücher

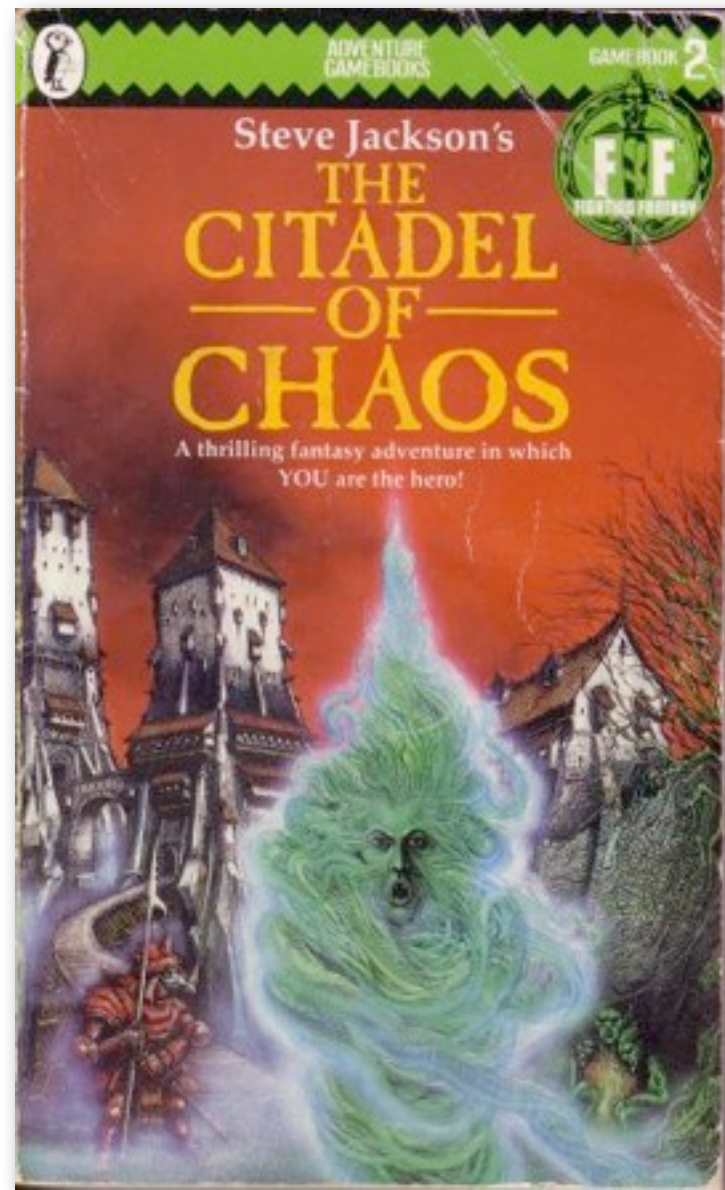

Fighting Fantasy



Choose your own Adventure
Lonely Wolf

The image is a screenshot from the 'Choice of the Dragon' game. At the top, there is a black bar with character stats: Brutality (red), Cunning (red), Disdain (red), Infamy (white), Finesse (blue), Honor (blue), and Vigilance (blue). Below the stats is a question: 'How do you defend yourself, O mighty dragon?'. There are two radio button options: 'I take to the air with a quick beat of my wings.' (selected) and 'I knock the knight from his horse with a slap of my tail.' At the bottom right, there is an 'OK' button.

Brutality Finesse
Cunning Honor
Disdain Vigilance
Infamy
OK

How do you defend yourself, O mighty dragon?

I take to the air with a quick beat of my wings.

I knock the knight from his horse with a slap of my tail.

Choice of the Dragon

<http://www.choiceofgames.com/dragon/>

Interactive Fiction

Watling Street

The Meteor, the Stone and a Long Glass of Sherbet

The Interactive Memoirs of a Diplomat

Copyright (c) 1996 by Angela M. Horns

Winning entry in the 1996 Interactive Fiction Competition

(Please type "help" if you would like instructions.)

Release 2 / Serial number 961216 / Inform v6.10 Library 6/3

Standard interpreter 1.0

Watling Street (in the cushioned basket)

The ancient paved road stretches for miles to the south, turning very slowly to the northeast along a mossy stone wall. From up here on your elephant's wickerwork basket, you're just level with the branches of the old Imperial hunting woods inside the wall.

Having been stuck in this cushioned basket with the Lady Amilia every day for a fortnight, you're just desperate to get away.

The procession of elephants shuffles on, their enormous soles slapping onto the flagstones with a dull, regular boom.

> |

Interactive Fiction Archive
<http://www.ifarchive.org/>

Baf's Guide to the IF Archive
<http://www.wurb.com/if/index>

rec.arts.int-fiction

<http://groups.google.com/group/rec.arts.int-fiction/topics>



<http://www.ifcomp.org/>

XYZZY news

<http://www.xyzzynews.com/>



XYZZY awards

<http://xyzzyawards.org/>

Z-Machine

Joel Berez; Marc Blank, 1979



<http://www.ifarchive.org/indexes/if-archiveXinfocomXinterpreters.html>

Interactive Fiction Writer



Andrew Plotkin

<http://www.eblong.com/zarf/home.html>

Graham Nelson

<http://www.gnelson.demon.co.uk/>

Inform 7 (2007) / Deform

<http://inform7.com/>

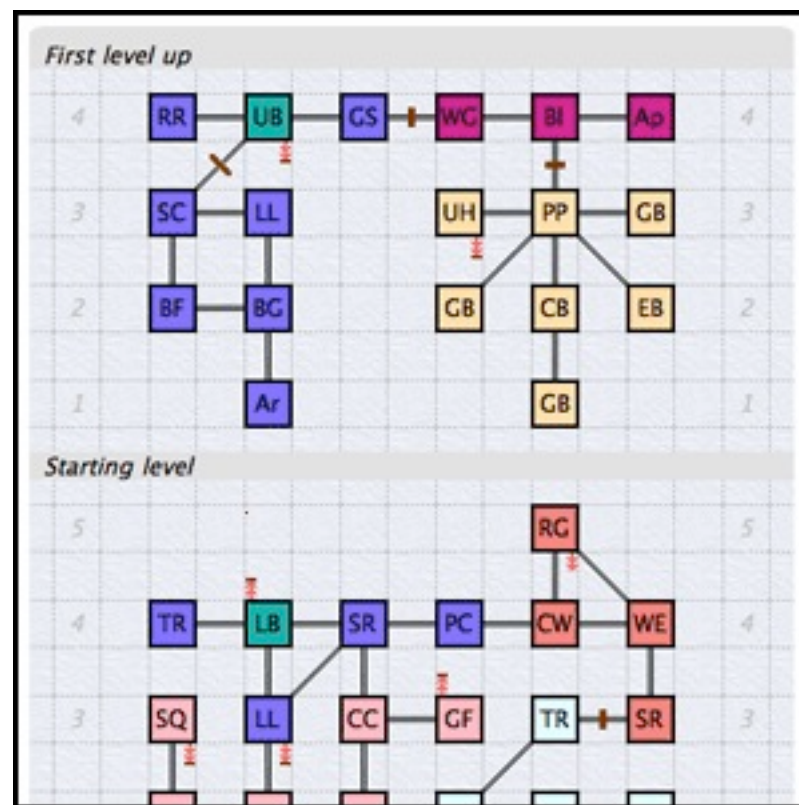

Graham Nelson

Seit 1993

Deutschsprachige Textadventures

<http://ifiction.pageturner.de/index.html>



<http://ifiction.pageturner.de/inform7/>

TADS 3 (2006)

<http://www.tads.org/>

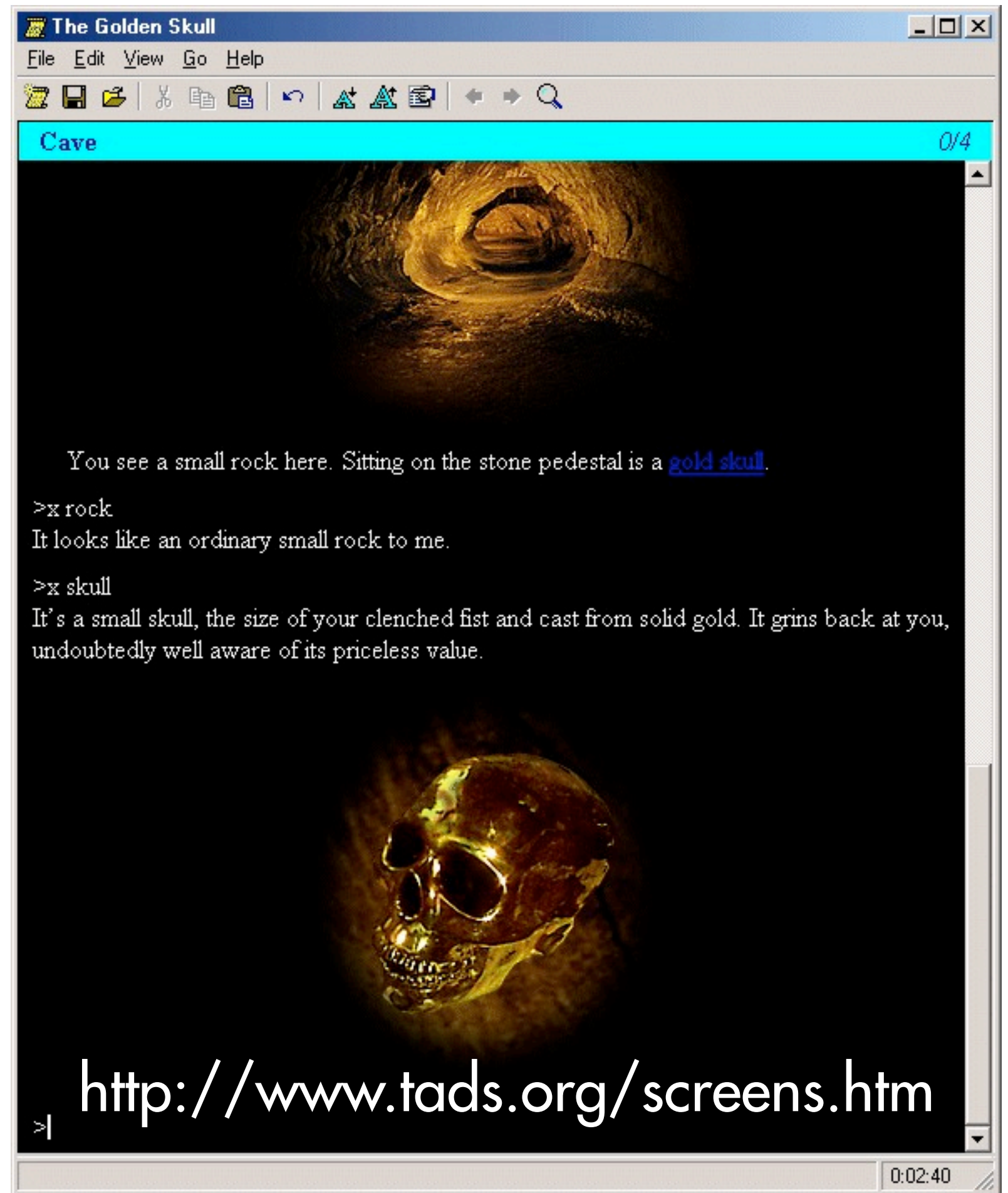

Adventure Games Live

<http://www.rinkworks.com/adventure/>

Adventure Games Live

The Trainer

Assault On Vampire Island

Fantasy Quest

Fantasy Quest II

The Game of the Ages

The Perils of Akumos

Trail of Anguish

Starlight Sacrifice: Preview #2

The Mystery of Brackly Hall

Outlaws of the Sierra Nevadas

The Early Years

More Early Years

Escape From St. Mary's

Fan Projekte



Every Cloak Has A Silver Lining
Part One: Shadows

<http://www.adventuregamers.com/underground.php>

<http://www.adventuregamesite.de/fan-adv.htm>

King's Quest: The Silver Lining
<http://www.tsl-game.com/>



ifmud

ifMUD

a MUD forever voyaging

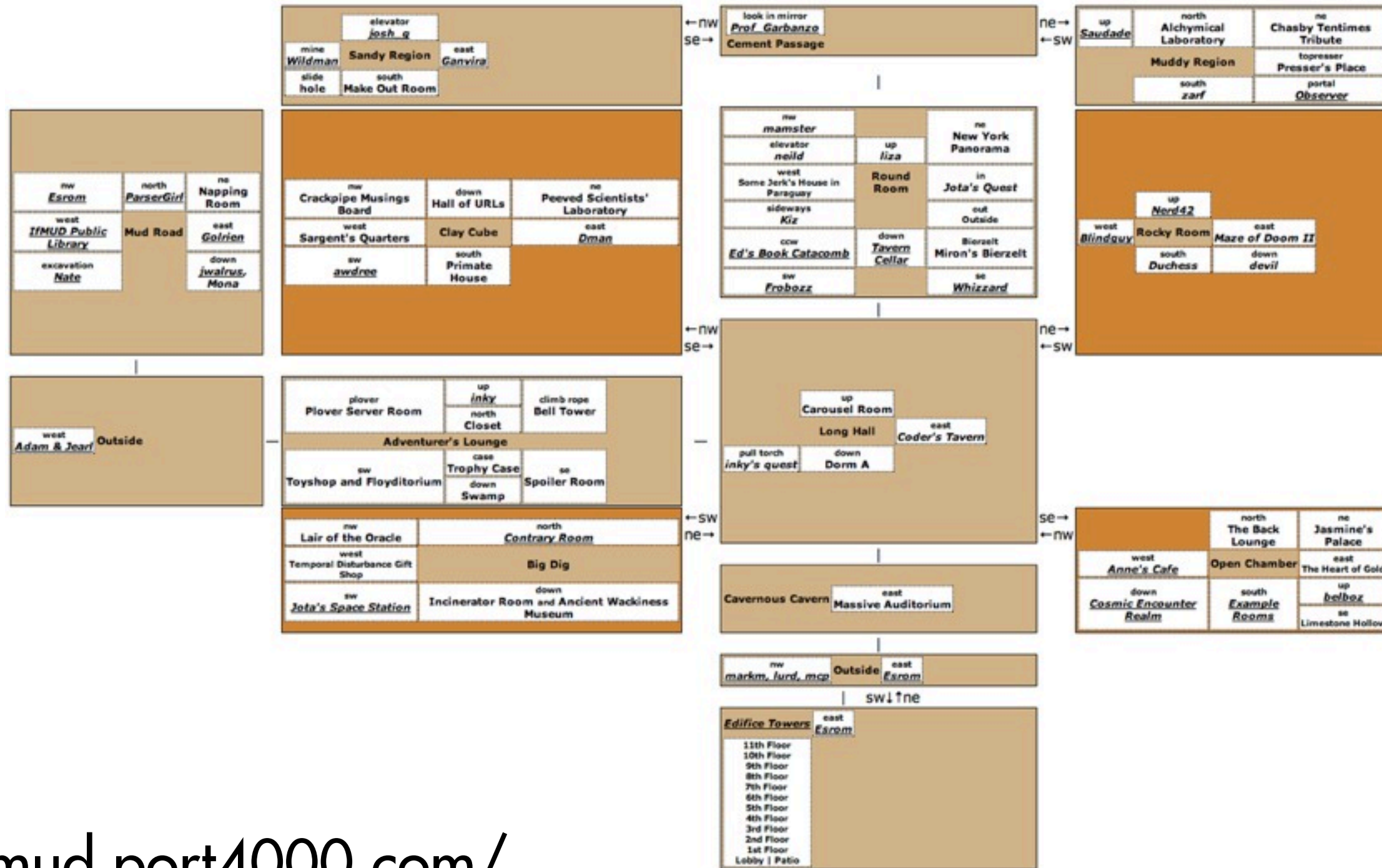

<http://ifmud.port4000.com/>

SPAG

<http://www.sparkynet.com/spag/>



Adventure Game Studio

<http://www.adventuregamestudio.co.uk/>

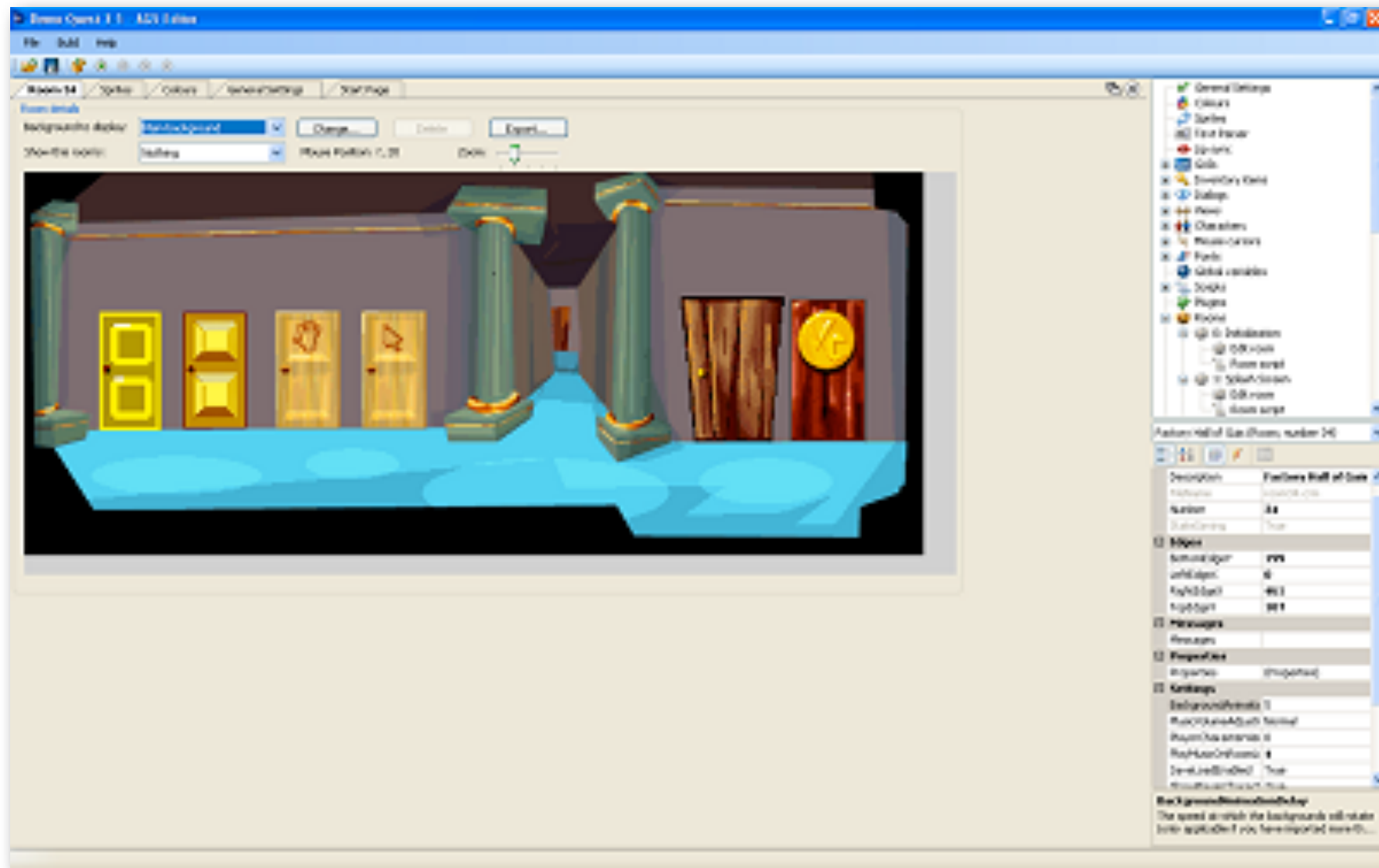

Monthly AGS Competition (MAGS)

AGS Team Challenge (ATC)



Professor Neely And The Death Ray Of Doom



A Tale of Two Kingdoms

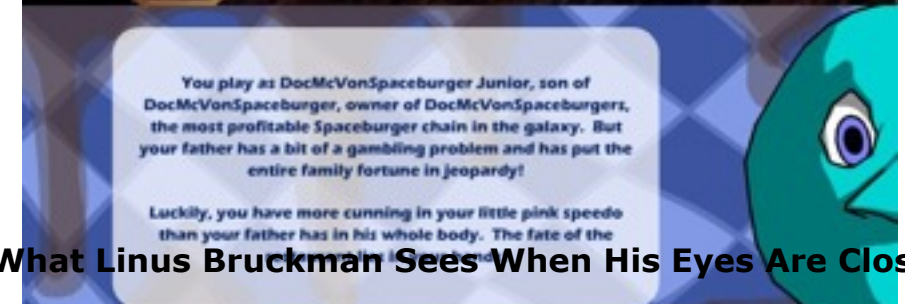
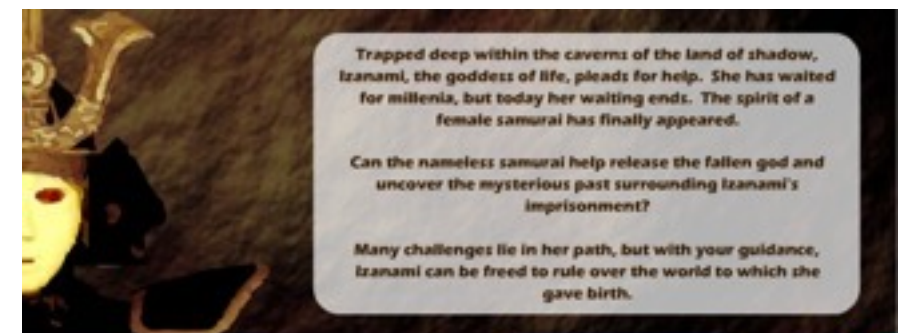

Web-Adventures

Johnny Rocketfingers



The Several Journeys of Reemus



Submachine



Escape the Room

<http://jayisgames.com/tag/escape>



Crimson Room



Mystery of Time and Space (MOTAS)

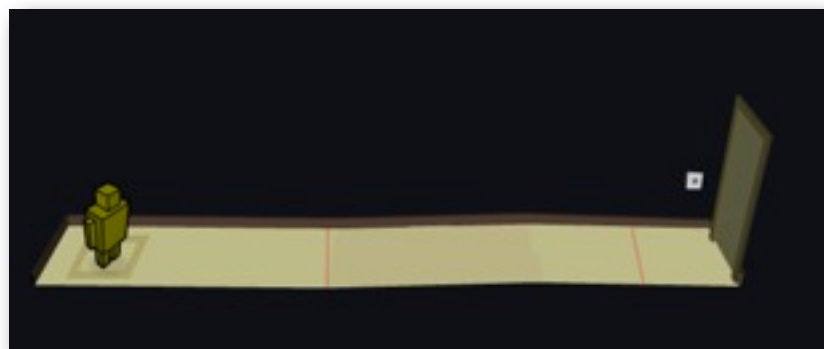

Gateway

The Dream Machine

<http://www.thedreammachine.se/>



1

Not Pron

KOMM HIERHEIN!

<http://www.deathball.net/notpron/>

Feed the Head

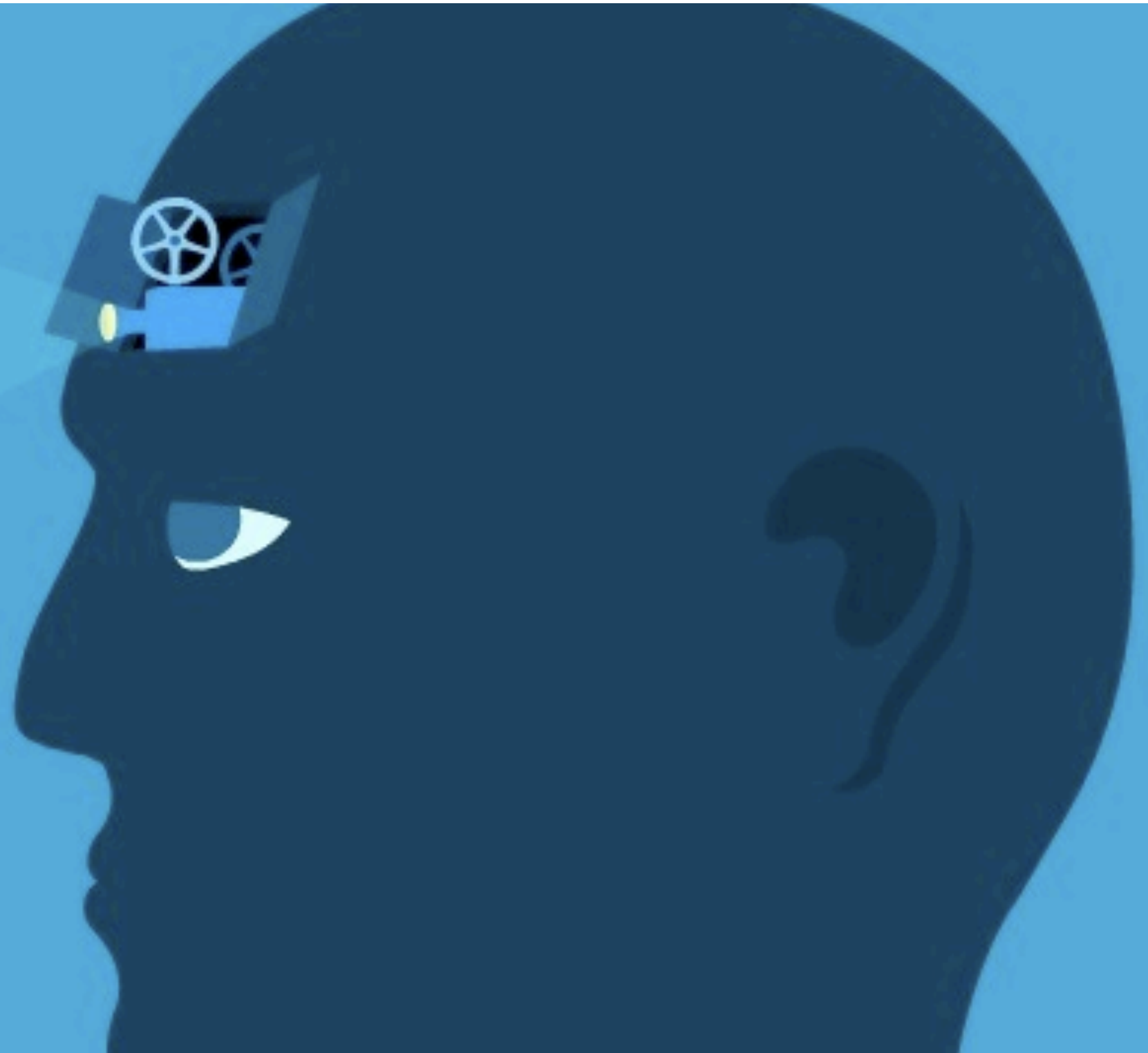

<http://www.feedthehead.net/>

Explore the bio-bak

<http://www.bio-bak.nl/>



GPS Mission

<http://gpsmission.com/>

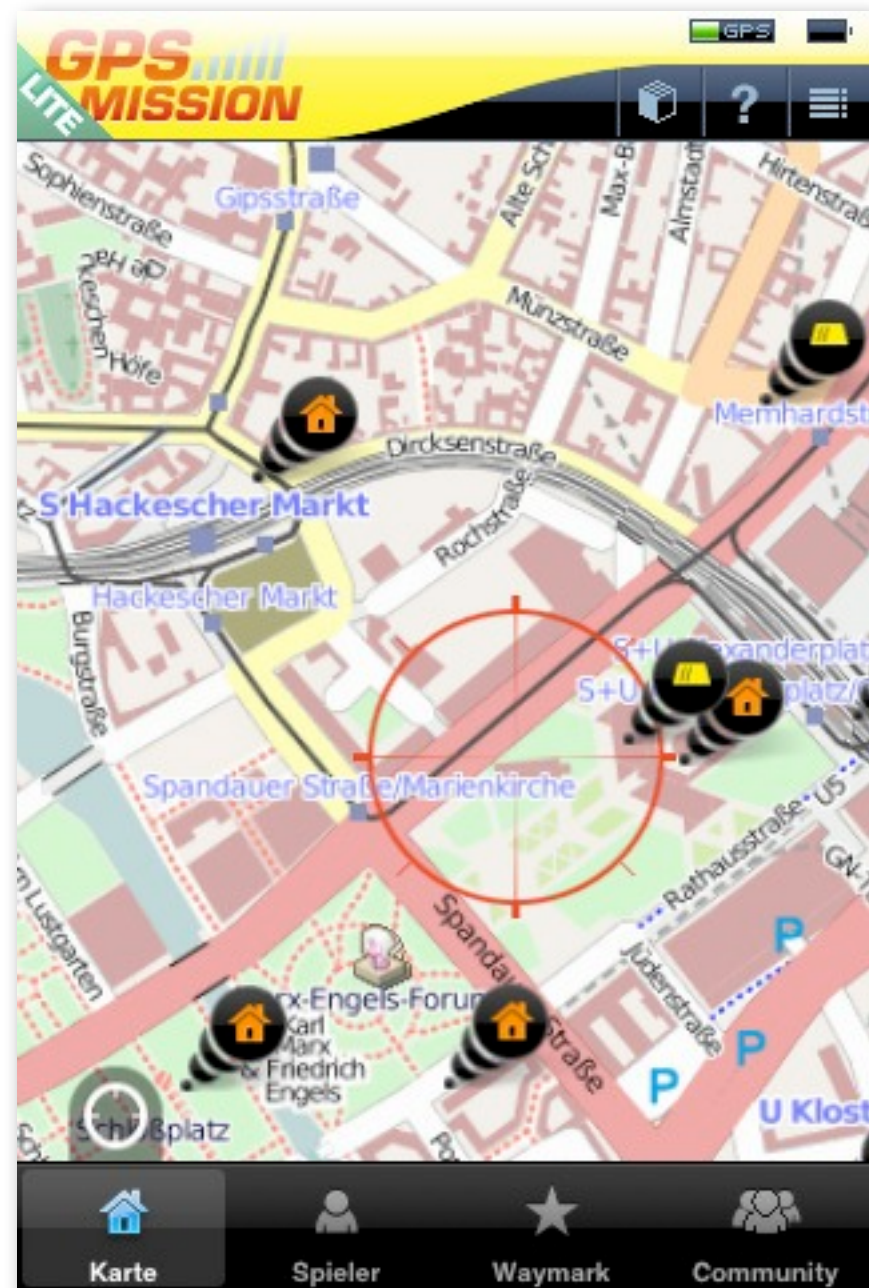

Mixed Reality Adventures

<http://urban-interactive.com/>

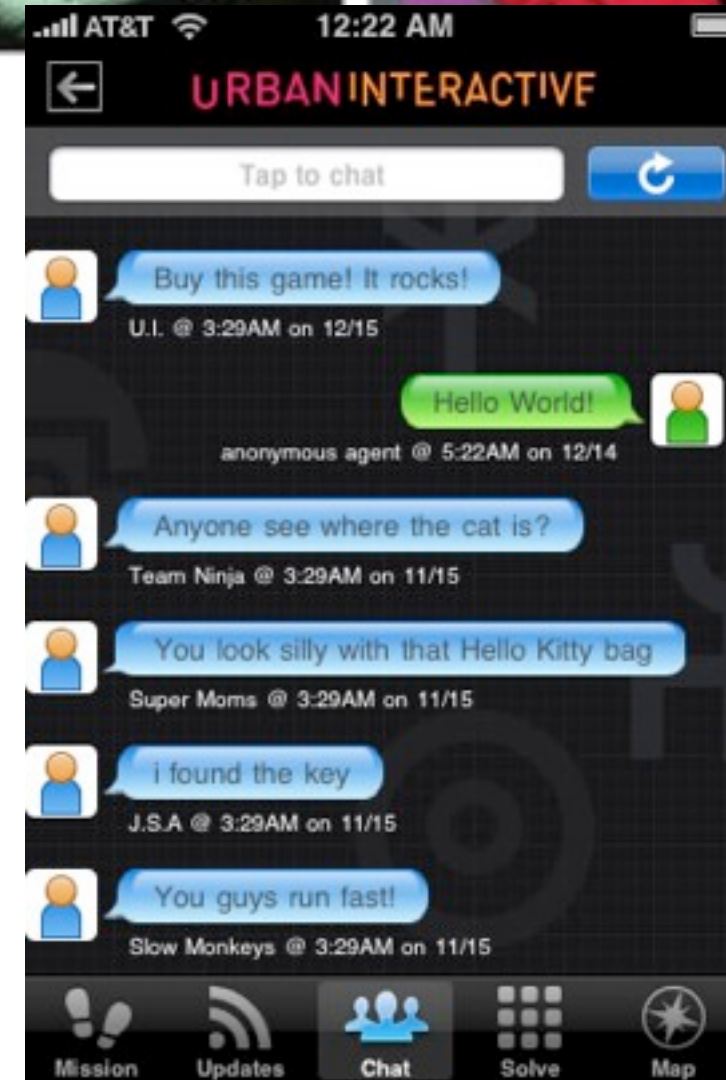
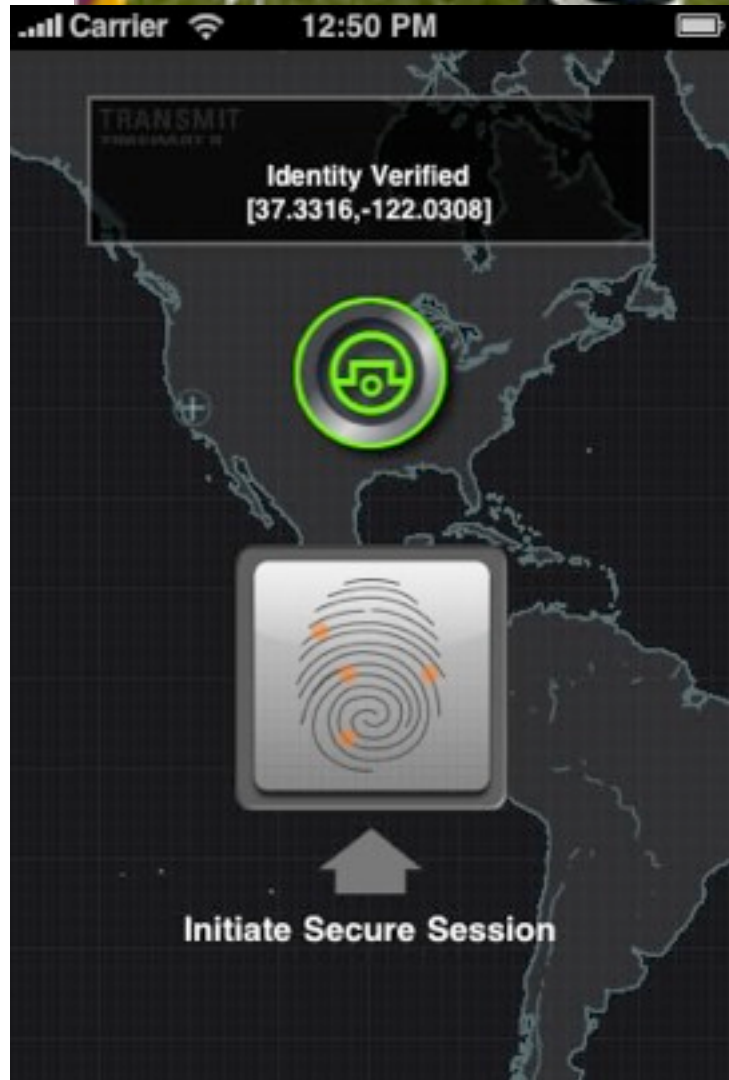

Mobile Storytelling

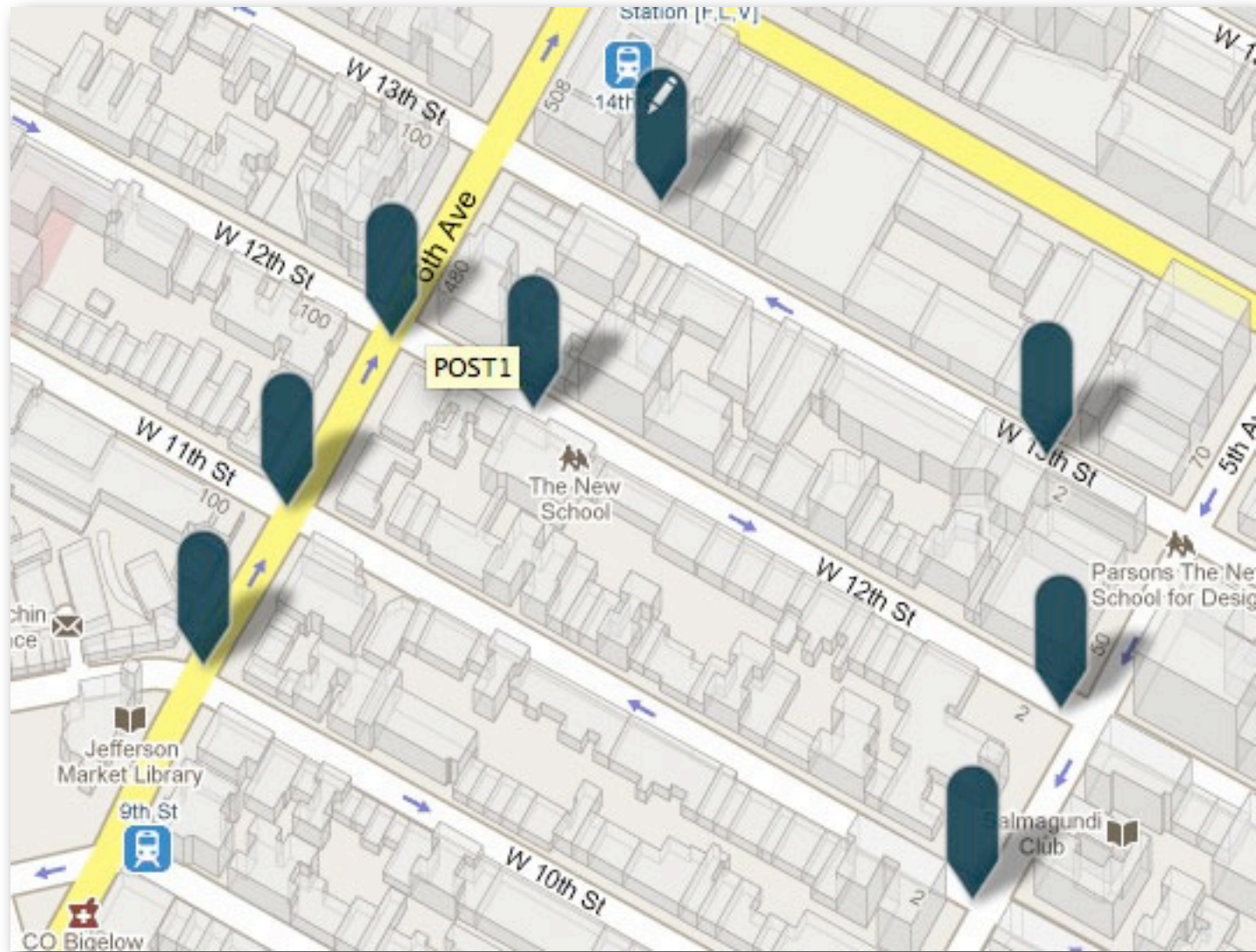

<http://7scenes.com/>



Alternate Reality Games



We Tell Stories

Sony Xi